

CellDesigner™

Ver. 3.5

Startup Guide



Updated January 10th 2006 for Version 3.5.1

CellDesigner is being developed by

The Systems Biology Institute
<http://www.systems-biology.org/>

Mizuho Information & Research Institute
<http://www.mizuho-ir.co.jp/>

Mitsui Knowledge Industry Co. Ltd.
<http://bio.mki.co.jp/en/index.html>

Acknowledgements:

Rainer Machné and Christoph Flamm
of the theoretical biochemistry group, University of Vienna
for SBML ODE Solver integration.

Frank Bergmann and Herbert Sauro
had implemented a new Simulation Driver module for SBW-2.x.

[Table of Contents]

What's New in CellDesigner™ 3.5.....	4
[CellDesigner 3.5 Major Features].....	4
[CellDesigner Major Features:].....	4
Startup Guide.....	5
1 Installation and Startup.....	5
1.1 Operating Environment.....	5
1.2 Install SBW and SBW Modules.....	5
1.3 Install CellDesigner.....	5
1.4 Startup CellDesigner.....	8
1.5 CellDesigner Screen and Navigation.....	9
2 Quick Tutorial of Model Building.....	10
2.1 Open a File:.....	10
2.2 Select an Item:.....	10
2.3 Move / Delete an Item:.....	11
2.4 Compartment:.....	11
2.5 Undo / Redo:.....	11
2.6 Change the size of an item:.....	11
2.7 Change the Shape of Compartments:.....	11
2.8 Species and Reactions:.....	12
2.9 Activate a Species:.....	13
2.10 Create New Species, Reactions, and Compartment:.....	13
2.11 Create a Complex:.....	14
2.12 Complexes and Reactions.....	14
2.13 Edit Reactions:.....	15
2.14 Change Color and Shape:.....	16
2.15 Smoothen an Image - Anti-Alias:.....	16
2.16 Export Image:.....	16
2.17 Save a Model:.....	16
2.18 Export a Model to pure SBML format:.....	16
3 Edit Species.....	17
3.1 Edit Species.....	17
3.2 Export Lists to CSV file:.....	17
3.3 Add Notes to the Components:.....	18
3.4 Connect to Databases.....	19
4 Edit Proteins.....	21
4.1 Check and Change Protein Property.....	22
4.2 Residue of Proteins.....	22
4.3 Block Diagram – to check Relationship of a Species (*Proto-type).....	23
5 Convenient Edit Functions.....	25
5.1 Temporal “select/move” mode.....	25
5.2 Cut, Copy and Paste.....	25
5.3 Select All.....	26
5.4 Grouping.....	26
5.5 Alignment.....	26
5.6 Fine tuning by keyboard operation.....	26
5.7 Set Grid Snap ON/OFF.....	26

5.8 Zoom IN/OUT, Bird's Eye View	26
5.9 Change Color and Shape	27
5.10 Display special characters in Component name	27
5.11 Automatic Layout.....	28
6 Simulation	29
6.1 Simulate a model by using Control Panel	30
6.2 Setup for Simulation via SBW	30
6.3 Simulate a model via SBW.....	31
6.4 Data required for Simulation.....	31
6.5 Data for Simulation: Sample MAPK.xml	32
7 Gene / RNA / AntiSenseRNA Structure Expressions.....	34
7.1 Promoter Structure Representation	34
7.2 Alternative Splicing	35
7.3 Identification of Gene, RNA, and AntiSenseRNA.....	35
8 Limitations and Known Issues.....	36
8.1 Limitations.....	36
8.2 Known Issues	36
Appendix 1: Symbols and Expressions.....	37
A1.1 Basic Symbols.....	37
A1.2 Expressions	42
Appendix 2: Sample Files for Graphical Notation.....	43
A2.1 Examples used in this document.....	43
A2.2 Examples for Graphical Notation.....	43

What's New in CellDesigner™ 3.5

CellDesigner 3.5 now supports automatic layout function using yFiles layout library. When you retrieve SBML files, the model is automatically layout according to the settings.

* Check <http://celldesigner.org> for details.

[CellDesigner 3.5 Major Features]

New feature and changes in CellDesigner 3.5 are as follows:

- New Features
 - [Layout] menu: Automatic Layout function (using yFiles layout library.) layout automatically when retrieving a SBML file.
 - Validate files when opening.
 - Native file chooser support for MacOSX.
- Bug Fixes
 - Fixing bug on PDF export.
 - Fixing bug to retain the annotations in SBML files created by other application.
 - Fixing bug on retrieving SBML file in which the reaction id is defined as only one letter.
 - Fixing bug on file opening: unable to open the file after deleting Compartments including Complexes or other Compartments.
 - Fixing bug on duplicating tags in Notes of the models created in previous versions of CellDeisgner.
 - Fixing bug on handling Groups with Complexes.
 - Fixing bug on simulating a model which contains MathML constant in kineticLaw.
 - Fixing bug on simulating a model with assignmentRules and rateRules.
 - Fixing bug on simulation result image export. (fix for 3.5.1)

[CellDesigner Major Features:]

- Easy to understand graphical notation
- Support Block Diagram (*Proto-type)
 - Extract the control relationship between Proteins from the pathway diagram.
 - Describe and Verify the Modifications/Activations Logic.
- Intuitive User Interface
- Extensive Notes Description (to Compartment, Species, Reaction, Protein)
- SBML Compliant (Level 2 Version 1)
- Output Lists to CSV format.
- Output Images in PNG, SVG, JPG, PDF formats.
- SBW 2.x support Direct Simulation with Control Panel
 - * See also separate document “*Running CellDesigner Simulation with Control Panel*”

Startup Guide

1 Installation and Startup

1.1 Operating Environment

The current version of CellDesigner requires Java5 Runtime Environment (J2SE Runtime Environment 5.0 or later) on Windows (2000 or later) and Linux with X Window System (Fedora Core 4 or later).

On MacOSX 10.4 or later, Java 1.5.0_03 or later is required. On MacOSX 10.3, Java 1.4.2_05 or later is required. On Linux platform, due to the version of native libraries, Fedora Core 4 or later is recommended; some problems will arise if you use other than these.

The installer includes JRE (Java Runtime Environment), so you do not have to install Java before your installation.

If SBW and its modules have already been installed, these modules are available. Especially time evolving simulation of editing models can be performed.

1.2 Install SBW and SBW Modules

If you are interested in time evolving simulation and analysis on biochemical networks, we recommend you to install the Systems Biology Workbench (SBW) and SBW-powered software before you install CellDesigner (*).

Please check <http://sbw.kgi.edu/> and download the software from Software/Download section.

To install SBW and SBW-powered software, follow their installation instructions.

If you would like to use CellDesigner alone right now, you can postpone this step until you need simulation and/or analysis.

(*) **As of Nov 2006**, SBW 2.6.0 is available.

For details on SBW information: <http://sys-bio.org/research/sbwIntro.htm>

1.3 Install CellDesigner

The current release is distributed in archived installer package for each operating system.

Windows: CellDesigner-351-windows-installer.exe
MacOSX: CellDesigner-3.5.1-osx-installer.zip
 CellDesigner-3.5.1-osx-panther-installer.zip (for
MacOSX 10.3)
Linux: CellDesigner-3.5.1-linux-installer.bin

While JRE is required for CellDesigner to run, the installers include it. Therefore, you do not need to download or install JRE.

Windows:

1. Double click `CellDesigner-351-windows-installer.exe`.
The installer window should open, and follow the message therein.
2. Follow the instruction of the installer.

MacOSX:

1. Double click `CellDesigner-3.5.1-osx-installer.zip` or `CellDesigner-3.5.1-osx-panther-installer.zip` for MacOSX 10.3 user.
The compressed installer should be recognized by Stuffit Expander and should automatically be expanded to `CellDesigner-3.5.1-osx-installer`.
2. Then double click it.
The installer window should open, and follow the message therein.

Linux:

1. Open a shell and, `cd` to the directory where you downloaded the installer.
2. At the prompt type:
% `chmod u+x CellDesigner-3.5.1-linux-installer.bin`
% `./CellDesigner-3.5.1-linux-installer.bin`
The installer window should open, and follow the message therein.

Note: In case you have installed SBW 2.5.5 and you encounter an error while installing CellDesigner, there might be a possibility that the C++ Broker is up which prevents CellDesigner to start. Please try to kill the broker using the Task Manager, or restart your system before you resume the CellDesigner installation.

[Installed File Images]

After installation finished, you would see the following directories/files in the installation directory (`CellDesigner3.5.1` by default).

```
+00README.txt
|
+CellDesigner3.5.1.exe    executable application module (* Windows only)
+CellDesigner3.5.1.sh    executable application module (* Linux only)
+CellDesigner3.5.1      executable application module (* MacOSX only)
|
+documents/
| +startupguide351.pdf   this document
| +controlpanel30.pdf    quick tutorial for control panel
|
+exec/
| +celldesigner.jar       library for CellDesigner application
| +autolayout_yobf.jar
| +yObf.jar
```

```

|
+jre (1.5.0)                *(Windows, Linux only)
|
+lib
| +batik.jar
| +browserlauncher.jar
| +freehep-graphicsio-ps-2.0.jar
| +freehep-io-2.0.1.jar
| +freehep-graphicsio-2.0.jar
| +freehep-util-2.0.1.jar
| +freehep-swing-2.0.2.jar
| +freehep-export-2.0.3.jar
| +freehep-graphics2d-2.0.jar
| +itext-1.4.6.jar
| +jai_codec.jar
| +jai_core.jar
| +jcommon-1.0.0-pre2.jar
| +jfreechart-1.0.0-pre2.jar
| +mlibwrapper_jai.jar
| +MRJAdapter.jar
| +openide-lookup-1.9-patched-1.0.jar
| +quaqua-filechooser-only.jar
| +sbmlj.jar
| +SBWCore.jar
| +xercesImpl.jar
| +xml-apis.jar
|
+libsbml.dll                *(Windows only)
+msvcp71.dll                *(Windows only)
+msvcr71.dll                *(Windows only)
+sbmlj.dll                  *(Windows only)
+SODE.dll                   *(Windows only)
+xerces-c_2_7.dll           *(Windows only)
|
+libSODE.so                 *(Linux only)
+libsbml.so                 *(Linux only)
+libsbmlj.so                *(Linux only)
+libxerces-c.so.27          *(Linux only)
|
+libquaqua.jnilib          *(MacOSX only)
+libsbml.dylib              *(MacOSX only)
+libsbmlj.jnilib           *(MacOSX only)
+libSODE.jnilib            *(MacOSX only)
+libxerces-c.27.dylib       *(MacOSX only)
|
+licenses/
| +celldesigner/
| +license.txt
| +libraries/
| +batik.LICENSE.txt
| +batik.NOTICE.txt
| +FreeHEP.LGPL.txt
| +FreeHEP.LICENSE.txt

```

```

+itext-MPLICENSE.txt
+jai.LICENSE.txt
+jfreechart.LICENSE.txt
+libsbml.LICENSE.txt
+mrjadapter.LICENSE.txt
+quaqua.LICENSE.html
+xerces.LICENSE.txt
+xercesImpl.LICENSE.txt
+xercesImpl.NOTICE.txt
+xml-apis.LICENSE-SAX.html
+xml-apis.LICENSE.DOM-documentation.html
+xml-apis.LICENSE.DOM-software.html
+xml-apis.LICENSE.txt
+xml-apis.NOTICE.txt
+yfiles-3rdPartyLicenses.html
+yfiles-GeneralLicenseTerms.html
+yfiles-GeneralTermsandConditions.html

+samples/
+components.xml          sample for various components
+M-Phase.xml             sample for model editing
+M-Phase2.xml            sample for model editing
+MAPK.xml                sample for simulation provided by SBML ODE Solver
+simulation.xml          sample for simulation
+test-level1.xml         sample for SBML level 1 document
+test-level2.xml         sample for SBML level 2 document
+database.xml            sample for database connections
+nbt                      sample files used in Nature Biotech paper by Kitano
+notation                sample files for notation

+uninstall.exe          *(Windows only)
+uninstall               *(Linux only)
+Uninstaller            *(MacOSX only)

```

1.4 Startup CellDesigner

Windows:

1. Double click shortcut icon  CellDesigner3.5.1 in your desktop.
Or double click CellDesigner3.5.1.exe in the directory where you chose to install (C:¥Program Files¥CellDesigner3.5.1 by default).

MacOSX:

1. Double click  icon CellDesigner3.5.1 in the folder you chose to install (/Application/CellDesigner3.5.1 by default).

Linux:

1. On a shell, type ./runCellDesigner3.5.1 in your home directory.
Or type ./runCellDesigner3.5.1 after changing to the directory where you chose to install (CellDesigner3.5.1 in you home directory by default).

1.5 CellDesigner Screen and Navigation

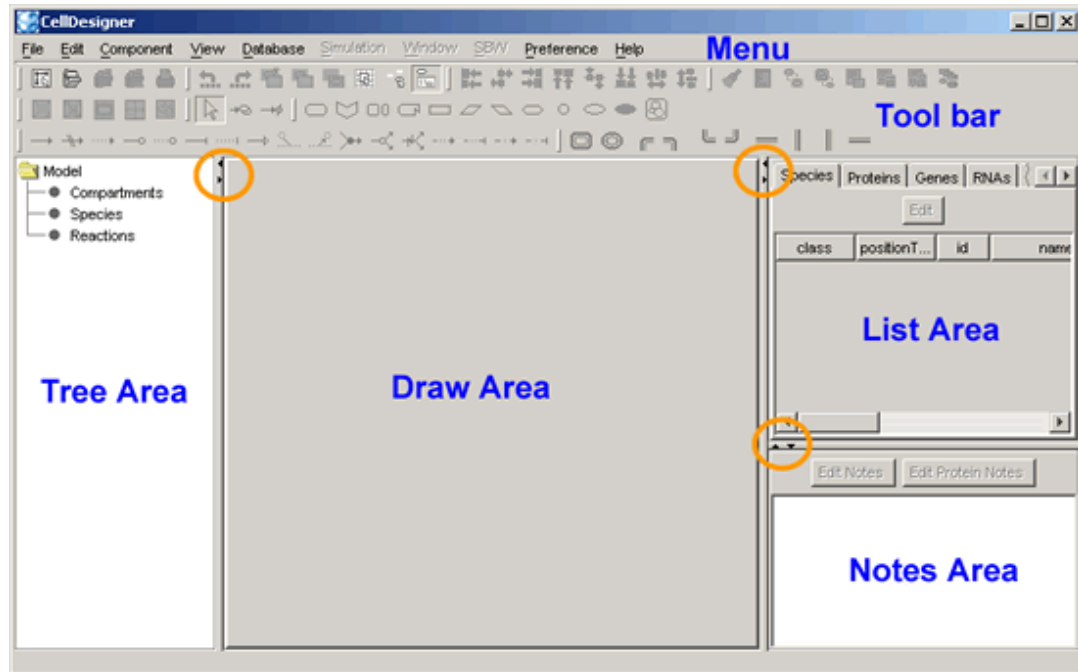

CellDesigner consists of four areas as shown above:

- | | |
|------------|--|
| Draw Area: | To draw a model. |
| List Area: | to display and edit the list of the components, functionsof a model |
| Notes Area | To display and edit the notes of the component |
| Tree Area: | Displays all the list of the components in the tree structure. |

Change the area size:

- The size of the area can be changed by dragging the borderlines.
- To maximize the area, click the triangle icons on the borders.

Customize Tool bar:

- Each group of the icons can be detached from the Tool Bar.
- It can also move to the left side of the screen by dragging the handle to the left boundaries.

2 Quick Tutorial of Model Building

This section is for beginners, and describes how to edit of the model with CellDesigner in brief.

Take a sample file “**M-Phase.xml**” to open in the CellDesigner. This model contains most of the essential CellDesigner's expression of biochemical networks.

2.1 Open a File:

1. Select File – Open in main menu bar to open M-Phase.xml in samples directory. A graphical network model is displayed on the Draw Area.

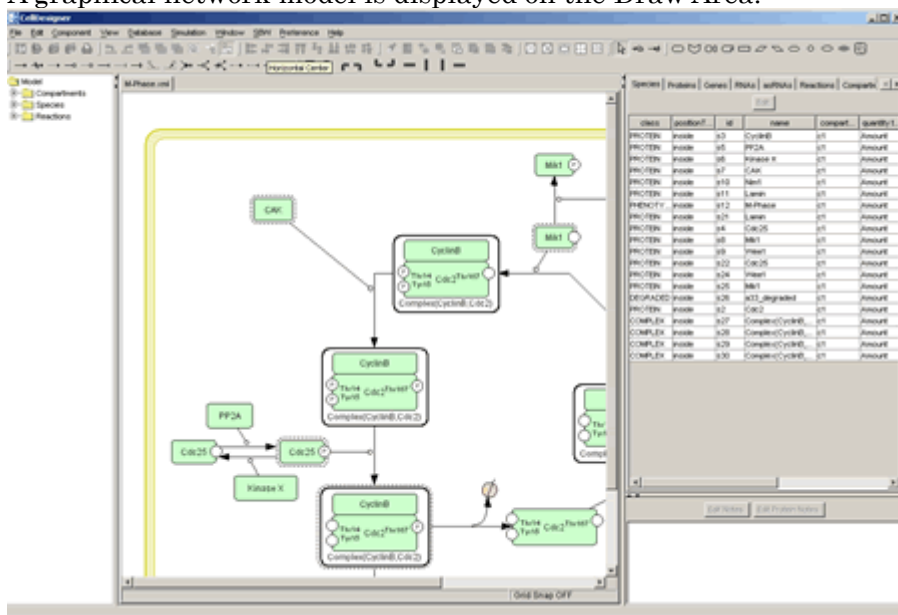

2. Drag the borders (left or right) of the draw area to change the area size

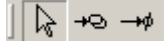

2.2 Select an Item:

3. Confirm "select/move" icon is highlighted (in select/move mode).
 If not, click the icon.
4. Select shapes (not arrows, not rounding overall; called **Species** in SBML), and see what are highlighted.
[Ans. The shapes and linked arrows.]
5. Select arrows (called **Reaction** in SBML), and see what are highlighted.
[Ans. The arrows and attached arrows.]

2.3 Move / Delete an Item:

The objects highlighted in magenta are influenced by "move" and "delete" actions to the selected object.

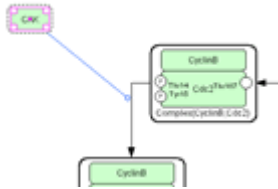

Now,

6. Drag and move the **Species**,
7. Delete the **Species** and **Reactions** by using Backspace and / or Delete keys.

2.4 Compartment:

The other shape rounding overall is called **Compartment** in SBML.

8. Click the Compartment (click inside without any other shapes), and see what are and how highlighted.

[Ans. The Compartment highlighted in magenta, **Species** inside shadowed]

A **Compartment** can place **Species** and other **Compartment** inside.

9. Drag and move the Compartment, and confirm **Species** inside are on it.

2.5 Undo / Redo:

You can "undo" all of the past actions by [CTRL]-z, and then "redo" after undo by [CTRL]-y before saving the model. Try

10. Undo by [CTRL]-z,
11. Redo by [CTRL]-y.

2.6 Change the size of an item:

When selecting the **Species** and **Reactions**, you can see small squares appear. These are handles to change the size of **Species** and to bend the arrows of **Reactions**.

12. Drag the small squares and move.

2.7 Change the Shape of Compartments:

A **Compartment** represents a generic bounded container, such as, cell, intracellular compartment. Thus, notational change is only in visual, meaningless to semantics of biochemical and gene networks.

To change the shape of **Compartment**:

13. Select the **Compartment**,
14. Select Component—Change to OVAL,
15. Then select Component—Change to SQUARE.

2.8 Species and Reactions:

The **Species** represents, for example, proteins and other molecules in biochemical networks and genes in gene regulatory networks.

The **Reaction** represents state transition of the connected Species, for example, biochemical reactions, interaction between proteins, and regulatory relations between genes.

The biochemical and genetic meanings of **Species** and **Reactions** are distinguished by their symbols. The list of all symbols that can be drawn using CellDesigner and their meanings are described in [Appendix 1 “Symbols and Expressions”].

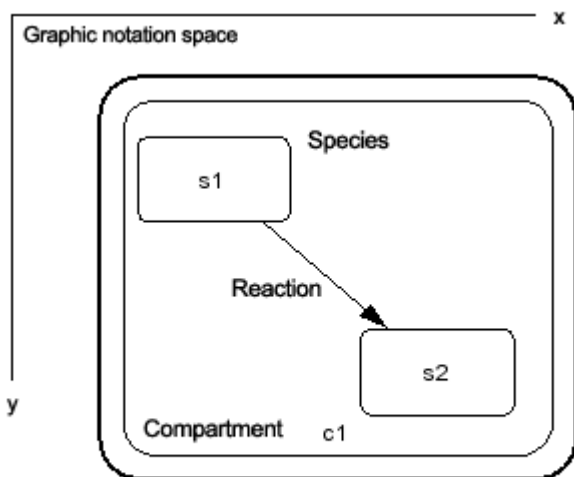

Symbolic process expression of the CellDesigner

To change the symbols of **Species / Reactions**:

If you double click **Species** and **Reactions**, the dialog box will appear to alter its properties.

16. Double click a **Species**, for example, “CAK”
“Change identity of the species” dialog is displayed.
17. Click and change “class” in the dialog box, and then, see what is changed after click "Apply" button.
You can switch from Protein to Gene, RNA, Ion etc. and vice versa.
18. Double click a **Reaction**,
click and change anything in the dialog box, and then, see what is changed after click "Apply" button.

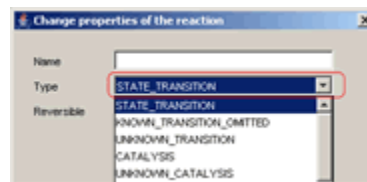
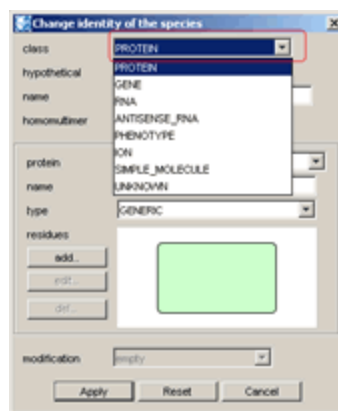

2.11 Create a Complex:

To Create a Complex

24. Click **Complex** icon from the icon tool bar.

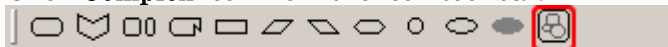

25. Place several **Species** inside it.

You can drag and drop the Species you want to add in the complex.

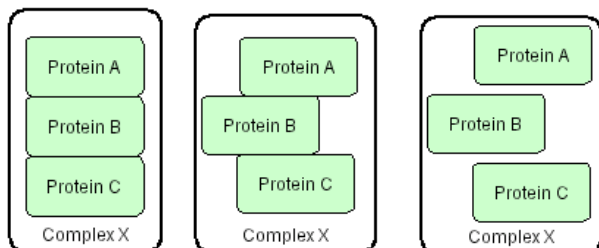

You can name the Complex of your choice. Name can be a simple name or a long name with all the names of the items included.

e.g. Complex(ProteinA,ProteinB,...)

Relationship between Complex and Species inside

You can modify the individual Species inside the Complex box at any time. For example, you can add a residue, change the residue status, or you can change the name or class of the Species.

The notes of the individual Species will be maintained even though you move the Species in and out of the complex box.

→ See also [3.3 “Add Notes to the Components”] and [4 “Edit Proteins”].

2.12 Complexes and Reactions

Reaction can be connected from the Complex or from the individual component inside the complex. For example, you can distinguish if the activation is initiated by the complex, or by an individual Species inside the Complex.

26. Select a Complex and type [C] to see it compact/expanded.

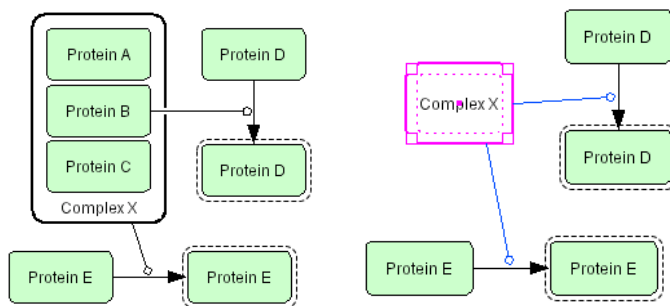

You can pack the Complex view to hide the included components by [Component]–[Change Complex View] menu.

2.13 Edit Reactions:

Connection Point of Reaction

Reactions can be connected to one of the 16 connection points around a Species.

27. Select a Reaction and try to change the connection point.



Anchor Points

You can add and remove Anchor points by the right click menu.

28. Select the point where you want to add the anchor, then click the right mouse button.

29. To remove the anchor point, click the right mouse button on the target anchor, then select “Remove Anchor Point”.

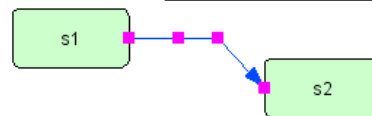
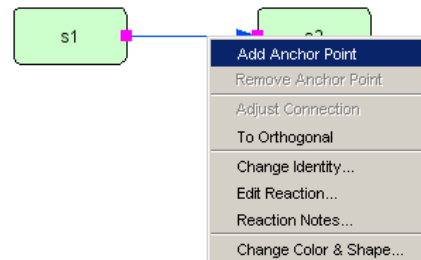

Move Segment

When the Species connected to the reaction is being moved, the last segment of the Reactions will be followed.

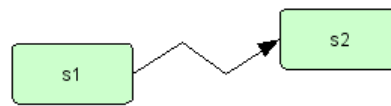

Drawing styles of the Connection

The shape of the Reaction can be changed to Orthogonal / to Polyline.

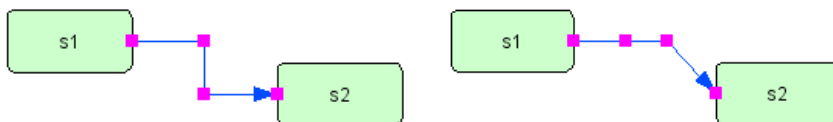

When you set the reaction to Orthogonal, you can adjust the drawing line by selecting “Adjust Connection” menu after having moved the Species connected to the reaction.

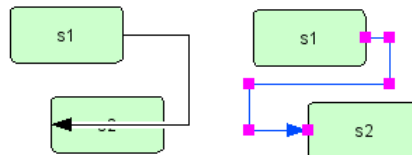

Line width and Colour Setting

Colors and line width of each Reaction can be specified as well as Species, and Compartment.

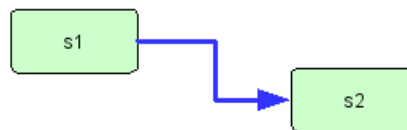

Reversible Reaction

To make a reaction reversible, set “Reversible” option “True” in “Change property of the reaction” dialog.



2.14 Change Color and Shape:

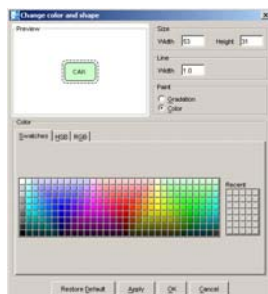

You can change the color and shape of the **Species** and **Compartments** individually or their default settings.

To change the default settings of the color and shape, select the Preference menu.

To change the color and shape of the individual components, select the components to edit, and then select the icon of

Change Color & Shape  in the tool bar.

2.15 Smoothen an Image - Anti-Alias:

30. Select the icon  of Anti-Alias in the tool bar.

You can get the smoother lines of Species and Reactions on canvas.

2.16 Export Image:

You can export the image of the model to .PNG, .JPEG, SVG or PDF format.

31. Select [File] – [Export Image...]

32. Then specify the name and the file format.

The image saved here is the same as displayed on screen.

2.17 Save a Model:

CellDesigner stores all the information on the model you create to SBML format file.

The CellDesigner's specific functions will be stored under <annotation> tag.

If you want to save the model in basic SBML information only, use "Export" function instead.

33. Select [File] – [Save] or [Save As...].

2.18 Export a Model to pure SBML format:

34. Select [File] – [Export Pure Level 2 Version 1...].

35. To import any SBML file, select [File]-[Open].

See also: For more details on SBML Levels, check <http://sbml.org/>.

3 Edit Species

3.1 Edit Species

To edit a Species, click on the target Species with the right mouse button, the pop-up menu will be displayed. All the operations that can be conducted with the target are displayed in the menu.

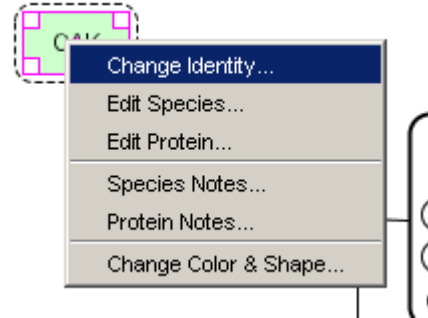

36. Right click on a Species, open menus to check how the properties are being set in dialogs.

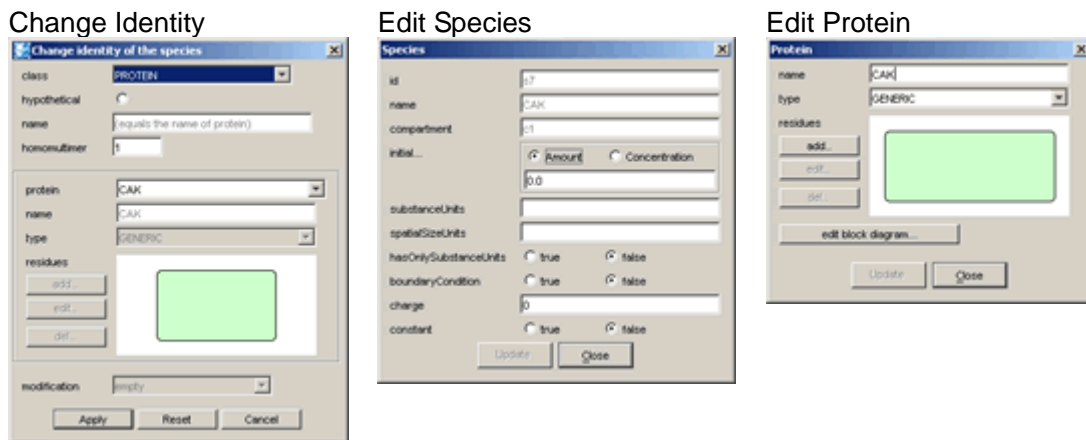

→ See also CellDesigner.org Online Help [Species] section: http://celldesigner.org/help/CDH_Species_T.html.

3.2 Export Lists to CSV file:

You can export the contents of the list into .CSV file format. This is useful when you want to check all the items specified in the model. All the lists you can see in the List window can be exported.

37. Select the [Species] tab in the list window.
38. Select [File] – [Export List to CSV...]. The file name is automatically specified as “M-Phase_species.csv” in the Save dialog.
39. Click [Save] to save the CSV file.

Species												
class	positionT	id	name	compart	quantityT	initialQuantity	substa	spatial	has	b.c.	ch	t
PROTEIN	inside	s3	CyclinB	c1	Amount	0.0		false	false	0	f	
PROTEIN	inside	s5	PP2A	c1	Amount	0.0		false	false	0	f	
PROTEIN	inside	s6	Kinase X	c1	Amount	0.0		false	false	0	f	
PROTEIN	inside	s7	CAK	c1	Amount	0.0		false	false	0	f	
PROTEIN	inside	s10	Nim1	c1	Amount	0.0		false	false	0	f	
PROTEIN	inside	s11	Lamin	c1	Amount	0.0		false	false	0	f	
PHENOTY	inside	s12	M-Phase	c1	Amount	0.0		false	false	0	f	
PROTEIN	inside	s21	Lamin	c1	Amount	0.0		false	false	0	f	
PROTEIN	inside	s4	Cdc25	c1	Amount	0.0		false	false	0	f	
PROTEIN	inside	s8	Mk1	c1	Amount	0.0		false	false	0	f	
PROTEIN	inside	s9	Wee1	c1	Amount	0.0		false	false	0	f	

You may use other applications to check the contents of the CSV file.

3.3 Add Notes to the Components:

You can add a note to any component (Species, Reaction, Compartment, and Protein). The notes should be written in XHTML format. For details on XHTML tags and attributes, please check the XHTML 1.0 specification provided at <http://www.w3.org/TR/xhtml1/>

You can enter PubMed ID in the notes, and directly link to the relevant reference.

→ See also [Section 3.4 “Connect to Database”].

To add a note to the component:

40. Select the target component (any Species, Reaction, Compartment, and Protein).
The current notes of the target component are displayed in the Notes window in the right-bottom corner of the window.
 41. Click [Edit Notes] button.
Species Notes dialog will pop-up.
- Note:** If the target is a protein, you can also select [Edit Protein Notes].
42. Type the text you want to add as the notes to the component.
The text should be in XHTML format.

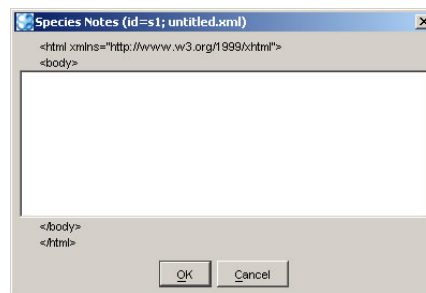

Then Click [OK] to close the dialog

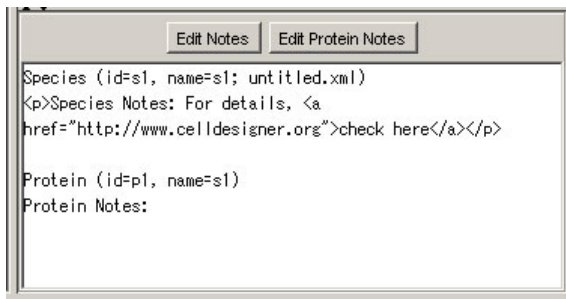

The notes you have just added will be displayed in the notes window.

3.4 Connect to Databases

You can connect to the databases from Species name or ID specified in the notes of the components. Currently we support the connections to the following databases:

- DBGET (a simple database retrieval system for a diverse range of molecular biology databases.)
- SGD (Saacharomyces Genome Database)
- PubMed
- Entrez Gene

Connect to the databases from Species Name:

43. Select the component (Species, Reaction or Compartment) then select [Database] -> [Connect to SGD], [Connect to DBGET], [Connect to iHOP] or [Connect to Entrez Gene].
According to the name of the Species, the web browser will pop up and open the relevant page.

Note: In case of DBGET, search is conducted according to the format of the name. If the name is written as "2.1.3.1", "EC2.1.3.1", "EC: 2.1.3.1", and "EC 2.1.3.1" for EC number, while the name start with "C", "C00010", "C 00010", "C: 00010", search for compound ID.

Connect to PubMed or Entrez Gene via the ID written in the Notes of the components:

44. Specify the PubMed ID / Entrez Gene ID in the notes of Species, Reaction, or Compartment as follows;
PMID: 12345 PMID: 67890
GeneID: 22954 GeneID: 493761
45. Select the component (Species, Reaction or Compartment) then [Database] -> [Connect to PubMed]

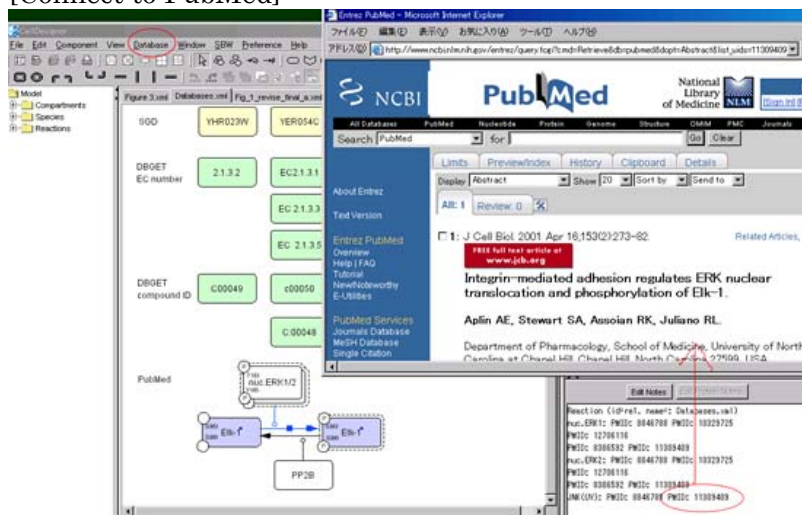

Connect to download the models from the databases:

CellDesigner can connect directly to BioModels.net, and import various annotated models.

BioModels Database (<http://biomodels.net>) is a data resource that allows biologists to store, search and retrieve published mathematical models of biological interests.

Models present in BioModels Database are annotated and linked to relevant data resources, such as publications, databases of compounds and pathways.

46. Select the menu [Database] – [Import models from BioModels.net...] to retrieve the models.



4 Edit Proteins

In this section, how to edit proteins with modification sites, such as "Cdc2" in the sample "M-Phase2.xml", is being described.

With CellDesigner, you can edit symbols of proteins with modification residues on a network diagram, and hence, describe detailed state transitions between **Species** of an identical protein with different modifications. The structure of modification residues, states, and state transitions of proteins are also stored in SBML Level 2 format with CellDesigner's extended tags.

The model M-Phase2.xml, you see, describes state transition of "Cdc2," where there are five "Cdc2"s. The five represent different **Species**, while essentially the same protein. Therefore, CellDesigner should handle data structure describing each protein in a model, so that several protein-type **Species** could have references to the same protein data. This data structure is called "**Protein**".

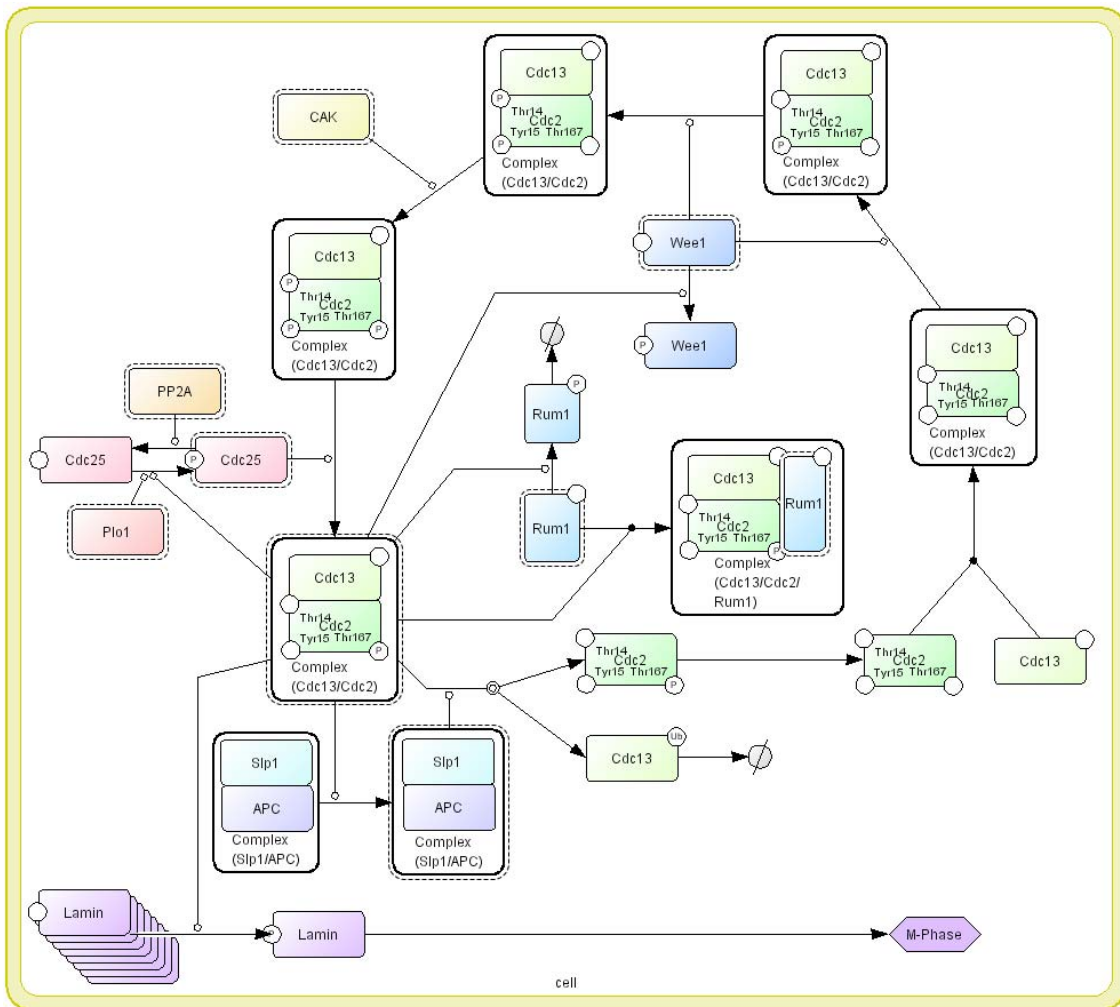

4.1 Check and Change Protein Property

You can see this Protein data by selecting the Protein tab in the List Area. If you cannot see the Protein tab, click on the right arrow in the upper right corner of the List Area, and adjust the size of the List window appropriately.

1. Select "Cdc2" in the list and click Edit button. The Protein dialog will appear. In this dialog, you can edit several properties of Protein, name, class, and residues (add, edit, and delete).

Alternatively, you can click on the target Protein with the right mouse button, to select "Edit Protein" menu.

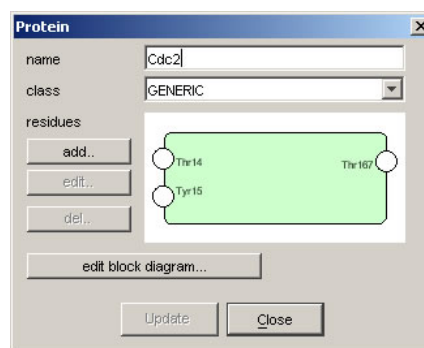

Changes in this dialog will be reflected to all **Species** referring to this Protein, including those inside Complexes.

4.2 Residue of Proteins

The residues of proteins can be added in the Protein dialog, but the modification of the residue status (such as phosphorylated, etc.) is NOT maintained as Protein's property, but as **Species'** identity.

1. Double-click **Species** in "select/move" mode to open "Change identity of the species" dialog. In the dialog, you can change the modification types.

Note: You cannot add, edit, or delete modification residues in this "Change identity of the species" dialog.

You can select a Protein referred by the **Species** in the "Protein" pulldown in the dialog. If you want to edit new protein which is not listed in the "Protein" pulldown, select [New Protein] listed at the last. Only such case, you can add, edit, and delete residues.

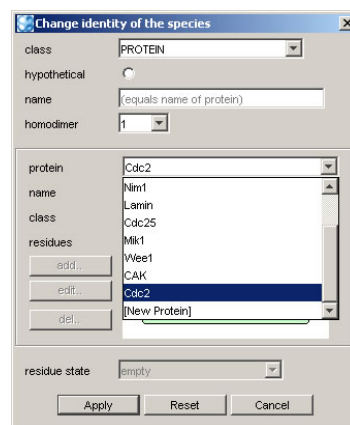

4.3 Block Diagram – to check Relationship of a Species (*Proto-type)

Block diagram gives a summary view of interactions with respect to a specific **Species** (especially **Protein**) and relation between its modification and activity as enzyme. Using this block diagram editor, complex relations between Proteins can be understood at a glance and the relation between modification states enzymic activity can easily be constructed.

Note: The editor is still prototype and user interface for editting is not fully functional.

Extract Regulation:

CellDesigner extracts the interactions where the **Species** regulates or is regulated by other **Species**, from process diagram, and displays its block diagram.

1. Open M-Phase.xml.
2. Right click on Species “Cdc2” then select “Edit Protein” menu. (See 4.1).
3. Click “edit block diagram” button and you can see the diagram as shown below.

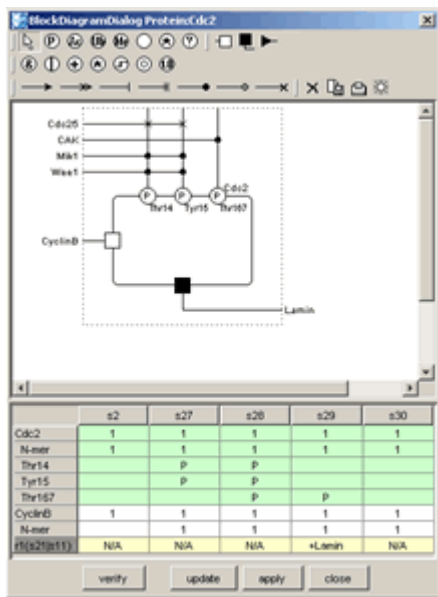

At the top side of the rectangle placed in center, states of modification residues of Cdc2 and proteins that cause change of the states (phosphorylate or dephosphorylate) are shown. At the left and bottom sides, binding to CyclinB enzymic activity to Lamina are shown respectively.

For notation details of the block diagram, see Kitano ([Biosilico 1, No.5 \(2003\) pp.169—176](#)).

List in the dialog shows all the **Species** of Cdc2 and Complexes with other **Species** in process diagram (column) and their modification states and enzymic activity (row).

Modifications/Activations Relation:

You can edit logical relation between modification states and enzymic acitivity.

1. Select the symbol “&” and then place them on the diagram.
2. Select the arrow, then link “P”, “&”, “□” and “■”.
[To delete a placed symbol, select the symbol and press × button in the toolbar.]

The arrows represent causal relationship and “&”, “|”, etc. are logical operators. Created logical relation can also be verified by checking consistency with contents of process diagram.

- Press “verify” button.

Enzymic activity fields inconsistent with edited logical relation are highlighted in red.

The left screenshot shows a signaling pathway diagram with a table below it. The table has columns for species s2, s27, s28, s29, and s30. The row for species s28 is highlighted in red, indicating an inconsistency. The right screenshot shows the same diagram and table, but the red highlight is gone, indicating a correction.

	s2	s27	s28	s29	s30
Cdc2	1	1	1	1	1
N-mer	1	1	1	1	1
Thr14		P	P		
Tyr15		P	P		
Thr167			P	P	
CyclinB	1	1	1	1	1
N-mer	1	1	1	1	1
[(s2)[s11]]	N/A	N/A	N/A	<Lamin	N/A

The above figures, the left is depicted by logical relation inferred by **Species** s29 only and the enzymic activity field of **Species** s28 is highlighted. The right is corrected by using the information of s28. (Note that the way of correction is not unique.)

5 Convenient Edit Functions

In this section, convenient functions for editing models are introduced. CellDesigner prepares several functions that are generally seen in drawing software.

5.1 Temporal “select/move” mode

When constructing a model using buttons on toolbars to create new **Species**, **Reactions**, and **Compartments** (in “create new” mode), you cannot move any components unless click the select/move icon. In model building, creating new components and layout them are likely to be repeated successively. In such case, holding “s” key on your keyboard down makes the current edit mode to “select/move” temporally. After moving some components by drag, releasing the key makes the edit mode to “create new” immediately.

Note: If you want to create components one by one, select “Input Repeat” in Edit menu to OFF the checkmark.

5.2 Cut, Copy and Paste

In “select/move” mode, selected **Species** can be cut / copied to CellDesigner’s internal clipboard by [CTRL]-x / [CTRL]-c, and pasted to the edit canvas by [CTRL]-v. The copy-and-paste action makes “real” copies of the selected **Species**, which are **SpeciesAliases** in CellDesigner’s terminology, referring the original **Species**. Strictly speaking, all of the **Species** on edit canvas are **SpeciesAliases** referring each original **Species**. By this feature, CellDesigner has multiple copies of the same **Species** on an edit canvas (i.e. a model), to possess ability to make various expression of a network.

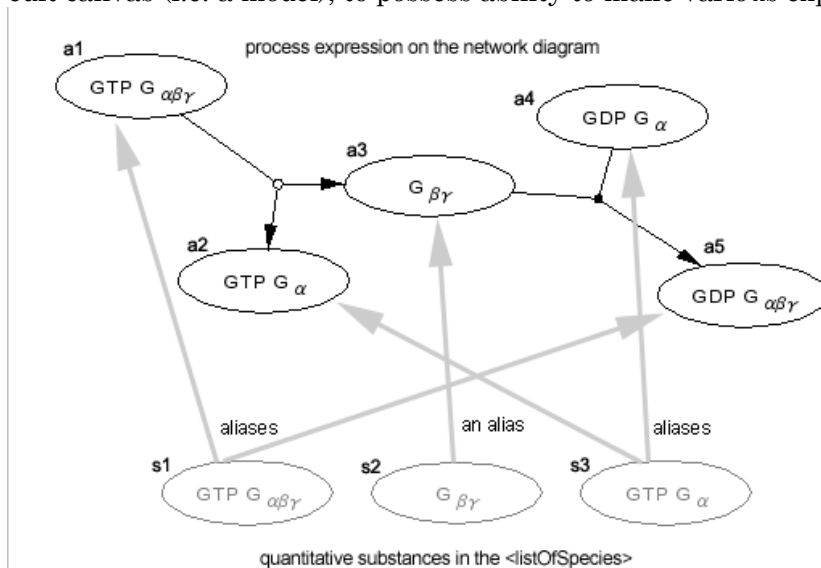

Fig. The Alias Structure of the CellDesigner

5.3 Select All

To select All the components in the model, [Ctrl]+A or specify [Select All] in the [Component] menu.

5.4 Grouping

In “select/move” mode, by clicking multiple **Species** while holding the SHIFT key down, you can make a temporal group of the selecting **Species**. Moving, cutting, and copying them in a group are available. If you want the group to be permanent (saved to SBML), use [CTRL]-g while the temporary group is formed. This grouping feature is resembled to the situation, **Species** on a **Compartment**, while it has nothing to do with structure of the model. Therefore, if these two conflict each other in the canvas, “**Species** on a **Compartment**” structure has priority.

5.5 Alignment

The following icons are available to adjust the alignment of the components. Select the multiple Species to adjust, and then click the icon of your choice.



5.6 Fine tuning by keyboard operation.

Species location can also be adjusted bit by bit using UP, DOWN, RIGHT, LEFT keys.

5.7 Set Grid Snap ON/OFF

Snapping components on grid makes it easier to layout the pathway diagram. Try the followings from Edit menu.

- Set Grids Size...
- Grid Snap
- Grid Visible

5.8 Zoom IN/OUT, Bird's Eye View

You can change the zoom of the display by clicking the following icons.



When you create a big model, it would be convenient to use the Bird's Eye View to navigate inside the model. The Bird's Eye View can be displayed by clicking the right most icon of the above tool bar. When you click, drag and drop in the Bird's Eye View, you can move to the specified position.

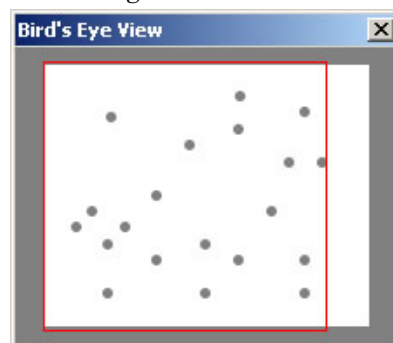

5.9 Change Color and Shape

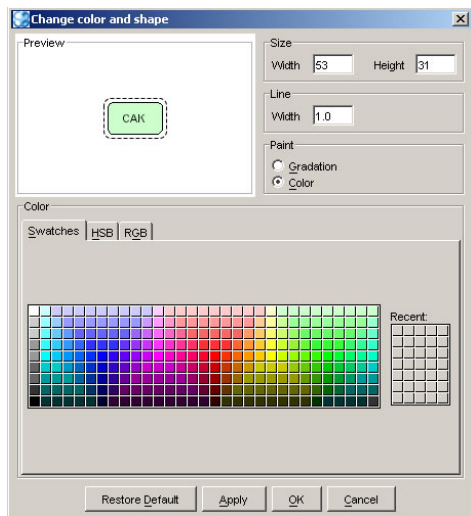

You can change the color and shape of the **Species** and **Compartments** individually or their default settings.

To change the default settings of the color and shape, select the Preference menu.

To change the color and shape of the individual components, select the components to edit, and then select the icon of Change Color & Shape



in the tool bar.

5.10 Display special characters in Component name

As CellDesigner is compliant to SBML, all names of components in a model must be conforming to the SBML convention. CellDesigner 2.0 is now compliant to SBML Level 2 Version 1; any character that can be mapped to UTF-8 encoding can be used for the component names. If you want the special characters, such as + plus, line break, superscript and subscript, you should follow the special rules to input such characters.

Examples:

A special character is expressed by a sequence of characters with precedent and follow up '_'s. Here are some examples:

1) Ca²⁺ ("Ca" with "2+" superscript)

- Ca_super_2_plus_endsuper_
- Ca_super_2+_endsuper_

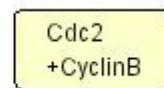
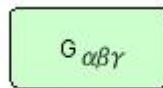

2) G alpha beta gamma ("G" with Greek "αβγ" subscripts)

- G_sub_alpha_beta_gamma_endsub_
- G_sub_αβγ_endsub_

3) Complex of Cdc2 and CyclinB ("Cdc2" followed by "+CyclinB" in the new line).

- Cdc2_br_plus_CyclinB
- Cdc2_br_+CyclinB

For more details on displaying special characters, check ["Name Expression" at Help menu.](#)

Caution: CellDesigner uses the "name" attributes as information to distinguish Species. Therefore, even if the rendered names look the same, the different "name" attributes, for example, "Gα" and "G_alpha_", mean different Species.

5.11 Automatic Layout

Automatic layout function is available for adjusting the model outlook.

When you retrieve SBML files created by other tools than CellDesigner without any layout information, it will automatically adjust the layout of the model with the layout schemes.

When you want to change the layout of your working models: Select [Layout] menu, then select the layout type:

- [Orthogonal Layout]
- [Organic Layout]
- [Smart Organic Layout]
- [Hierarchic Layout]
- [Incremental Hierarchic Layout]
- [Circular Layout]
- [Tree Layout]
- [Orthogonal Edge Routing] or [Organic Edge Routing]

You can change the detail settings for the above types as well as default settings adopted when you retrieve SBML files.

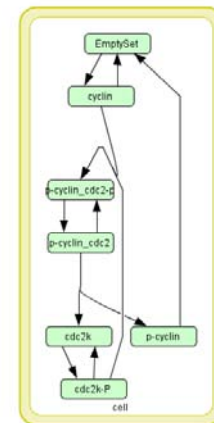
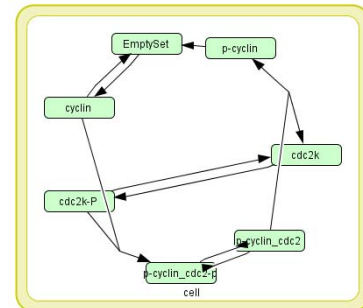
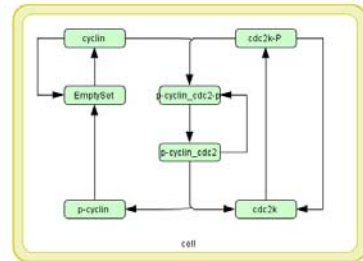

6 Simulation

In this section, we describe how to simulate a model.

CellDesigner can be used as a kind of SBML file editors for simulators.

There are two ways to conduct the simulation by CellDesigner:

- using Simulation menu to call SBML ODE Solver seamlessly. The conditions can be set using the Control Panel directly.
- using SBW menu to call SBML compliant simulators.

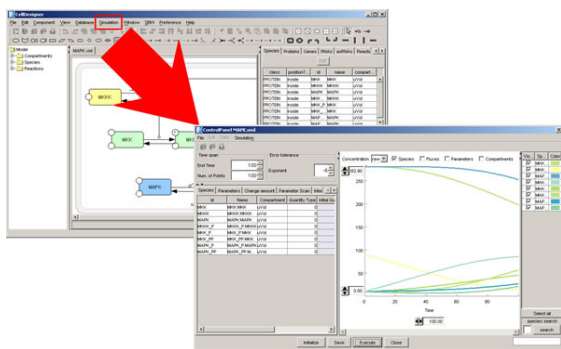

Simulation menu
for direct control over SBML ODE Solver

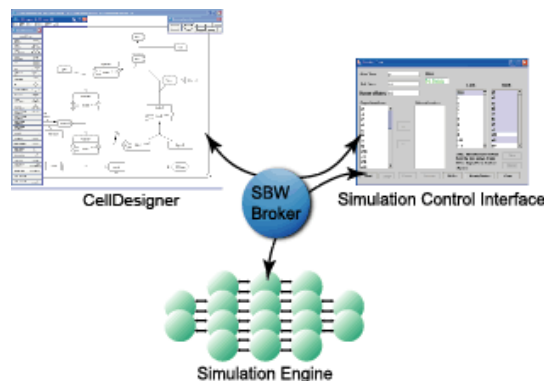

SBW menu
to call SBML compliant simulator.

If you select Simulation menu, you can call SBML ODE Solver directly. The ControlPanel enables you to specify the details of parameters, changing amount, conducting parameter search, and interactive simulation with intuitive manner.

If you select SBW menu, you can pass the SBML data from CellDesigner to the SBML compliant simulators via SBW. You can conduct simulation seamlessly from CellDesigner via SBW to evoke such SBML compliant simulators.

Note: You need to set up SBW before you conduct simulation.

To conduct time evolving simulation, you also need to know some basics of the SBML specification. Here in this document, describes the minimum requirements for simulation.

See also:

- For more details on SBML Level 1 specification, please check <http://sbml.org/specifications/sbml-level-1/version-2/sbml-level-1-v2.pdf>
- For SBML Level 2 specification, see <http://sbml.org/specifications/sbml-level-2/version-1/sbml-level-2.pdf>

Note: There are various annotated sample models at BioModels.net for simulation.

→ **See also** [Section 3.4 “Connect to Database”].

6.1 Simulate a model by using Control Panel

1. Open a SBML model to simulate.
2. Select “Simulation” - “Control Panel” menu.
The simulation control panel will be displayed.
3. In the control panel, click [Execute] button.
You will see the time course plot in the right side of the control panel.

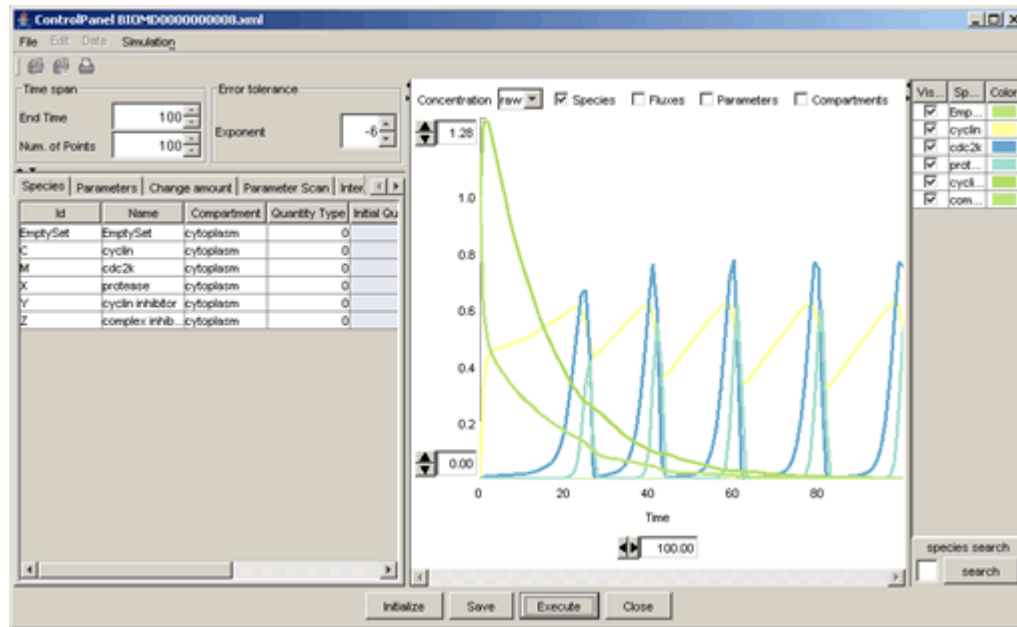

See also:

For more details on how to use control panel, please refer to the document “*Running CellDesigner™ Simulation with ControlPanel*” in the /documents directory.

6.2 Setup for Simulation via SBW

If you want to simulate with SBW modules you need to check if the SBW and SBW-powered simulator modules are installed in the path mentioned in Section 1.2 “Install SBW and SBW Modules”.

1. To check if the SBW is properly installed, start CellDesigner and open a model. SBW menu in the main menu is activated if your setup has correctly been done.
2. Check if there are any simulators listed in the SBW menu.
If you have installed the simulators of your choice correctly, they are listed under SBW menu. The following is the SBW menu in typical environment on Windows.

Typical SBW menu

- Simulation Service
- Save Model as Matlab ODE Function File

- Save Model as Matlab SimuLink Function File
- Jarnac Simulation Service

"Simulation Service" appears if Jarnac has been installed. The others are default-installed.

6.3 Simulate a model via SBW

Try simulation with a sample file:

1. Open `simulation.xml` in "samples" directory.
2. Choose Simulation Service from SBW menu.
This wakes Jarnac up and gives the model `simulation.xml` to it.
3. Check the help or manual of the simulator to learn how to start the simulation.

6.4 Data required for Simulation

From side of SBML model building, you should specify first at least some **Species** and its attributes, and **Reaction** and its attribute for simulation. The minimum requirement of their attributes might be:

- | | | | |
|--------------------|-------------------------------|--------------------|-----------------------------|
| • Species: | -initialAmount (default=0.0), | | |
| • Reaction: | -reactant: | -SpeciesReference: | -stoichiometry (default=1), |
| | -product: | -SpeciesReference: | -stoichiometry (default=1), |
| | -kineticLaw: | -formula, | |
| | | -parameter, | |

where the rightmost of each line is required to be input.

Species Attributes

The attribute "initialAmount" should usually be changed to a positive value.

The attribute "formula" should be text string according to SBML [Level 1](#) specification, probably including id (name in SBML Level 1) attribute of **Species** and parameters defined by the attribute "parameter." These attributes can be set at the Species list shown in the List Area.

Reaction Attributes

The attributes and parameters of the **Reaction** can be specified at the Reaction dialog and their child dialogs.

For the other parameters required, the default values specified in SBML Level 1 are used.

6.5 Data for Simulation: Sample MAPK.xml

Let us check the sample file “MAPK.xml” to see how the data required for simulation is specified in the model.

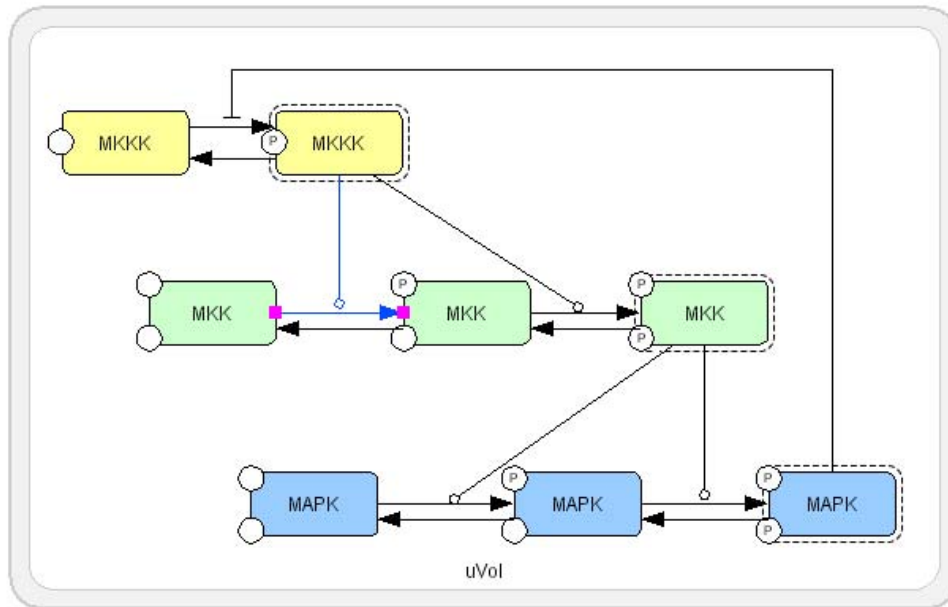

1. Open MAPK.xml in samples directory.
2. Check the Species list in the List Area and check the initial quantities.

Species												
class	positionT...	id	name	compart...	quantity t...	initial...	substa...	spatial...	has...	b.c.	ch...	cons...
PROTEIN	inside	MKK	MKK	uVol	Amount	280.0			false	false	0	false
PROTEIN	inside	MKKK	MKKK	uVol	Amount	90.0			false	false	0	false
PROTEIN	inside	MAPK	MAPK	uVol	Amount	280.0			false	false	0	false
PROTEIN	inside	MKK...	MKKK	uVol	Amount	10.0			false	false	0	false
PROTEIN	inside	MKK_P	MKK	uVol	Amount	10.0			false	false	0	false
PROTEIN	inside	MKK...	MKK	uVol	Amount	10.0			false	false	0	false
PROTEIN	inside	MAP...	MAPK	uVol	Amount	10.0			false	false	0	false
PROTEIN	inside	MAP...	MAPK	uVol	Amount	10.0			false	false	0	false

3. Check the Reactions list in the List Area to see how the kinetic laws and parameters are specified.

Reactions											
list Of Reactions											
type	id	name	reve...	fast	reactants	products	modifiers	math			
STATE_TRANSITION	J0	J0	false	false	MKKK	MKKK_P	MAPK_PP	$V1 \cdot MKKK \cdot ((1 + pow(MAPK_PP, n)) / (K1 + M...))$			
STATE_TRANSITION	J1	J1	false	false	MKKK_P	MKKK		$V2 \cdot MKKK_P / (K2 + MKKK_P)$			
STATE_TRANSITION	J2	J2	false	false	MKK	MKK_P	MKKK_P	$k3 \cdot MKKK_P \cdot MKK / (K3 + MKK)$			
STATE_TRANSITION	J3	J3	false	false	MKK_P	MKK_PP	MKKK_P	$k4 \cdot MKKK_P \cdot MKK_P / (K4 + MKK_P)$			
STATE_TRANSITION	J4	J4	false	false	MKK_PP	MKK_P		$V5 \cdot MKK_PP / (K5 + MKK_PP)$			
STATE_TRANSITION	J5	J5	false	false	MKK_P	MKK		$V6 \cdot MKK_P / (K6 + MKK_P)$			
STATE_TRANSITION	J6	J6	false	false	MAPK	MAPK_P	MKK_PP	$k7 \cdot MKK_PP \cdot MAPK / (K7 + MAPK)$			
STATE_TRANSITION	J7	J7	false	false	MAPK_P	MAPK_PP	MKK_PP	$k8 \cdot MKK_PP \cdot MAPK_P / (K8 + MAPK_P)$			
STATE_TRANSITION	J8	J8	false	false	MAPK_PP	MAPK_P		$V9 \cdot MAPK_PP / (K9 + MAPK_PP)$			
STATE_TRANSITION	J9	J9	false	false	MAPK_P	MAPK		$V10 \cdot MAPK_P / (K10 + MAPK_P)$			

4. Double click on an item in the reaction list to display the “Reaction” dialog.

You can display “Reaction” dialog” by clicking on the reaction on canvas with right mouse button, then select “Edit Reaction” menu.

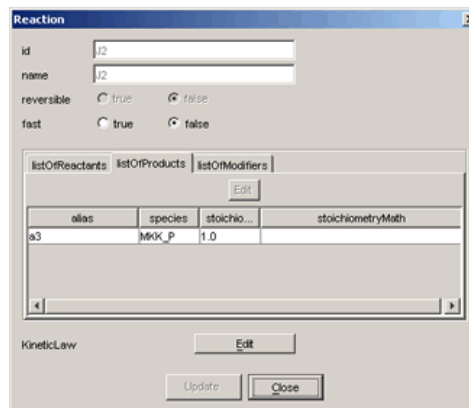

5. Click “KineticLaw” Edit button to display “KineticLaw” dialog.
6. Enter “math” formulae and edit parameters by clicking in the “listofParameters” section.

Note: In “math” formulae, Species ID, not Speices Name, should be specified.

To enter Species ID, you can click the target Species on canvas, and press [copy] button below the “math” field. The ID will be automatically input to the field.

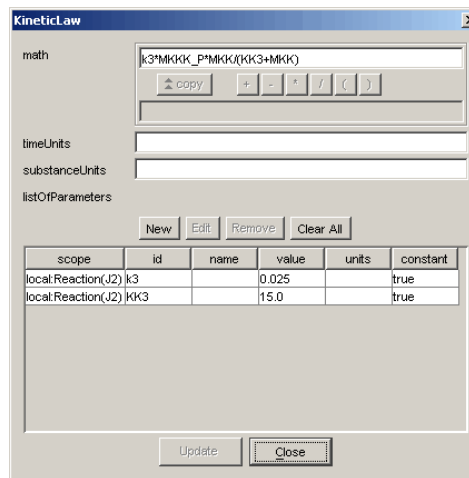

7 Gene / RNA / AntiSenseRNA Structure Expressions

The graphical notation is extended and redefined to enhance representation capability for transcription and translation processes. The most salient feature is capability to describe promoter structure, exon segments, and other detailed structure for genes and RNAs.

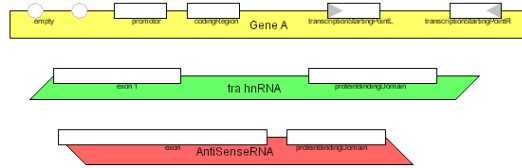

→ See also [Appendix 2: Sample Files fro Graphical Notation].

7.1 Promoter Structure Representation

A new extension allows user to define structure of promoter region, exon, and histones. Specific promoter regions, exon, and histon are represented on upper part of the box. When such structure information is defined, lines for both sides and lower part of the box are either not shown or dimmed to highlight structures represented on the upper line.

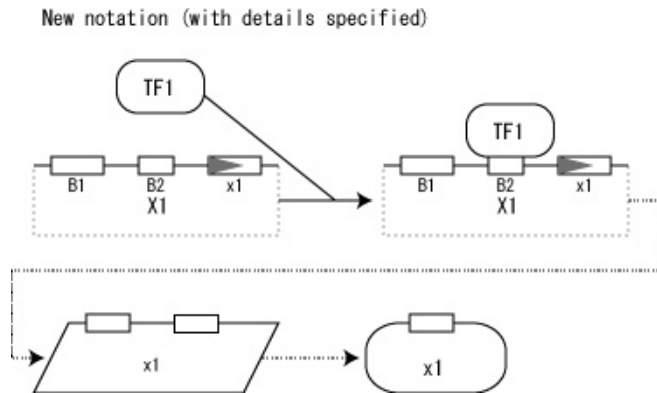

7.1.1 Symbols related to transcription and translation

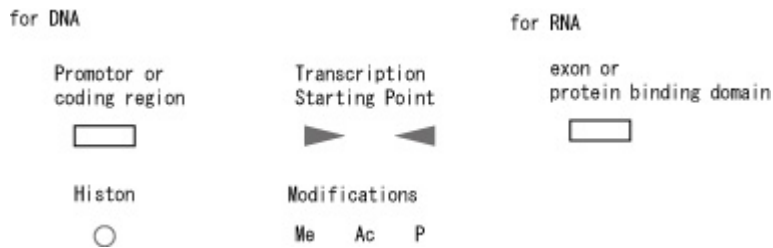

7.1.2 A usage example transcription related symbols

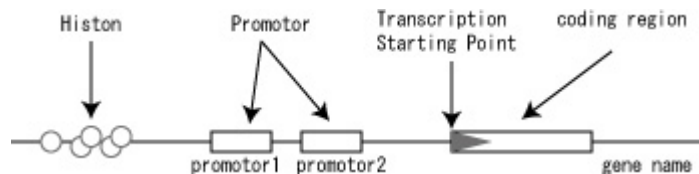

7.1.3 Specifying Region symbols and status

To specify the regions, click the target items and from the right click menu, select [Edit Gene/RNA/asRNA...]. Alternatively select the target from the Gene/RNA/asRNA lists. Add the region; select the type and location of your choice in the dialog box.

To change the status of the “empty” region of the gene, Select [Change Identity...] menu, click the target empty region and change the modification status.

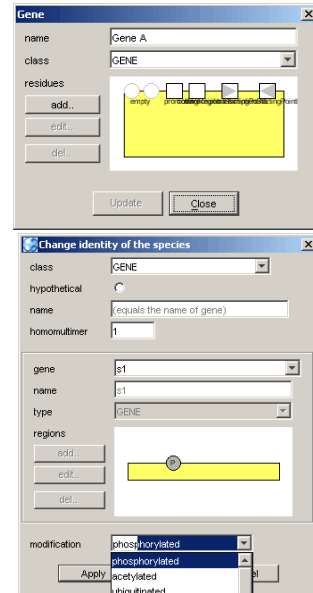

7.2 Alternative Splicing

Alternative splicing can be represented as transition of RNA from original state to multiple RNA with different splicing patterns.

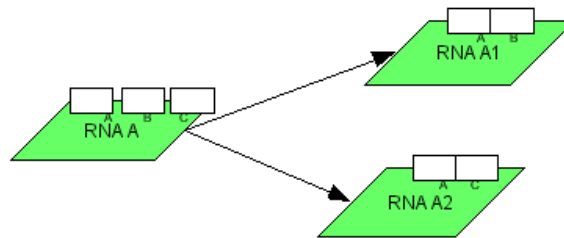

7.3 Identification of Gene, RNA, and AntiSenseRNA.

In the model, Genes, RNA and AntiSenseRNA are identified by their name. If the name of the newly created component is already available in the mode, the representation will become the same as the existing one.

8 Limitations and Known Issues

8.1 Limitations

- (a) Available actions of UNDO and REDO are limited to actions making change on the draw canvas.

8.2 Known Issues

- (a) The problems are reported in printing / exporting images of the huge model due to the lack of the memory.
- (b) When using CellDesigner in non-English environment on MacOSX and Linux, letters on dialog boxes from File menu are not correctly displayed.
 - **For MacOSX**, open “System Preferences” and click “International” icon from “Personal” row, and then click “Language” tab. In the window for choosing language, place “English” at the top. (Note: The terms quoted by “_” depend on your environment.) Then start CellDesigner.
 - **For Linux**, unset LANG in the shell, then starts CellDesigner.

Appendix 1: Symbols and Expressions

This section lists up all the symbols for building models with CellDesigner.

Graphical notation and the list of the symbols are based on the proposals by Kitano:







- <http://www.sbw-sbml.org/workshops/sixth/sbmlsbwstockholm.htm>, and
- "Using process diagram for the graphical representation of biological networks", Nature Biotechnology 23(8), 961-966 (2005).

The symbol system for state-transition diagram and the residue state representation in these proposals are mostly realized with CellDesigner.

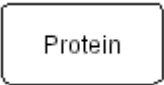
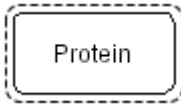
A1.1 Basic Symbols

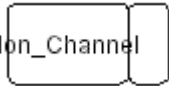
A1.1.1 Species

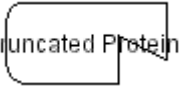
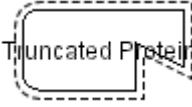
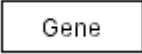
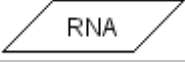
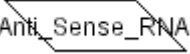
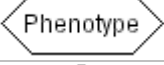
There are twelve types of **Species** symbols.

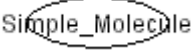
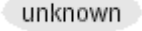
Species		activated
protein Generic		
protein Receptor		
protein Ion channel		
protein truncated		
gene		
RNA		
Anti-sense RNA		
phenotype		
ion		
simple molecule		
Unknown		

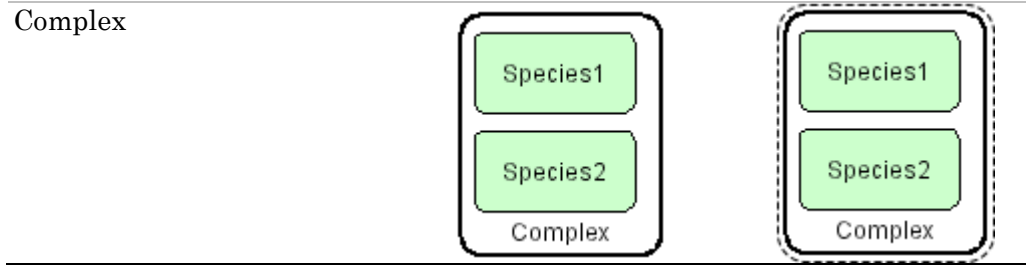

A1.1.2 Modifications of Protein Residues

There are seven types of symbols for residue modification states. The residue symbols accompanied with their label (used for residue name and position in amino acid sequence) can be attached to all protein-type **Species**.

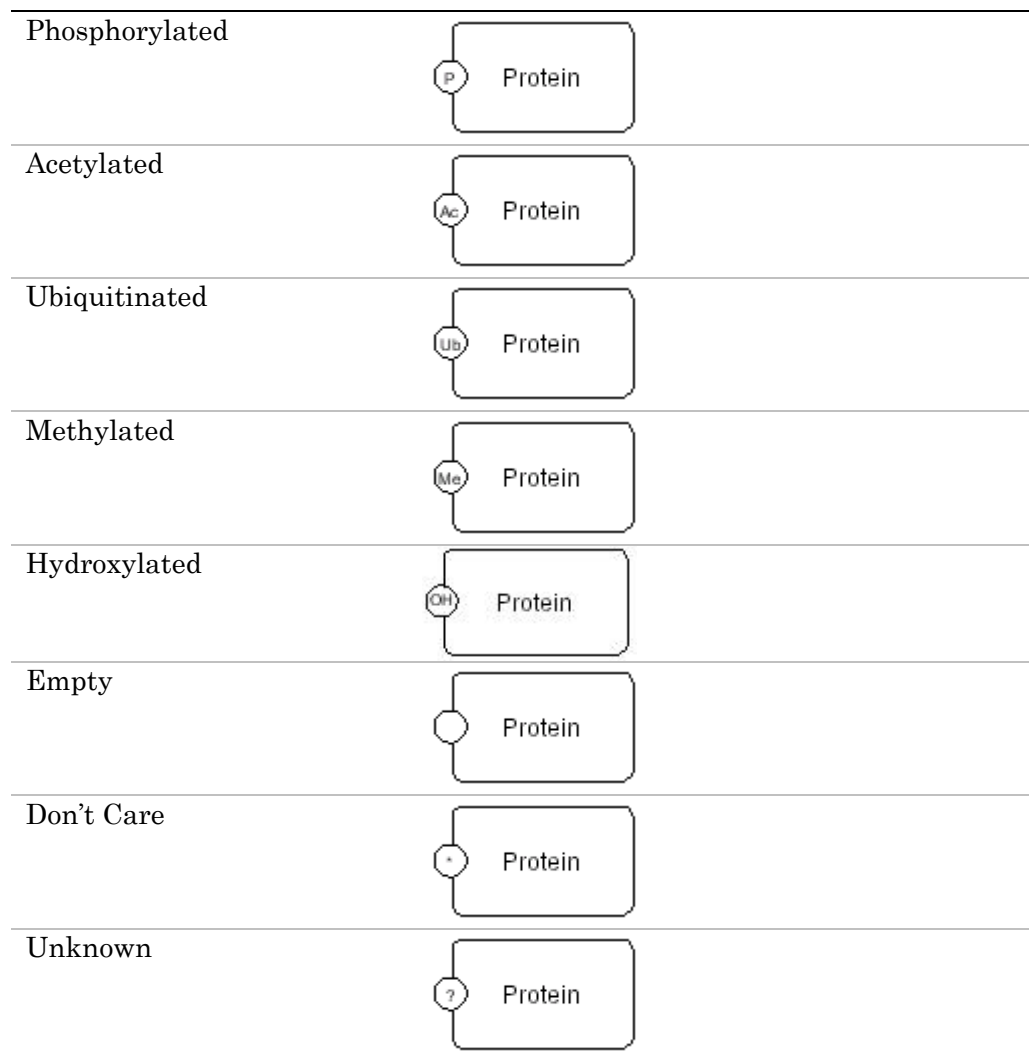

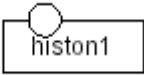
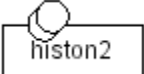
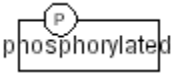
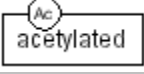
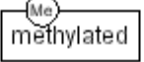

A1.1.3 Modifications of Gene / RNA / AntiSenseRNA Residues

There are seven types of symbols for residue modification states. The residue symbols accompanied with their label (used for residue name and position in amino acid sequence) can be attached to Gene / RNA / AntiSenseRNA.

histone1	
histone2	
phosphorylated	
acetylated	
methylated	

A1.1.4 Compartment

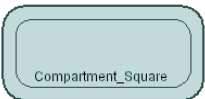
There are ten types of Compartment symbols. For each type, the thick line indicates outside of its boundary.

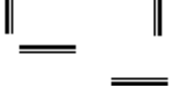
Square		
Oval		
Close-up type		Northwest, Northeast Southwest, Southeast
Close-up type		West, East North, South

A1.1.5 Reaction

There are thirteen types of **Reaction** symbols.

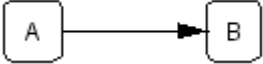
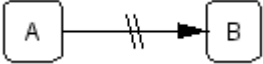
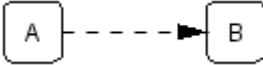
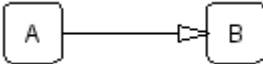
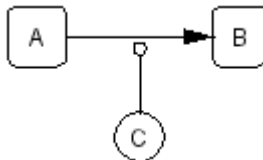
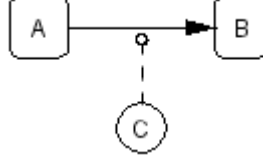
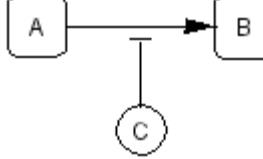
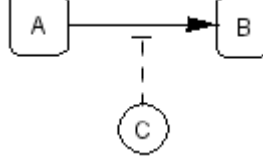
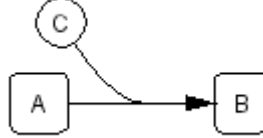
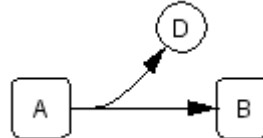
Reactions		
State Transition		
Known Transition Omitted		Abbreviated symbol of several Reactions
Unknown Transition		
Transport		
Catalysis		
Unknown Catalysis		
Inhibition		
Unknown Inhibition		
Add Reactant		
Add Product		

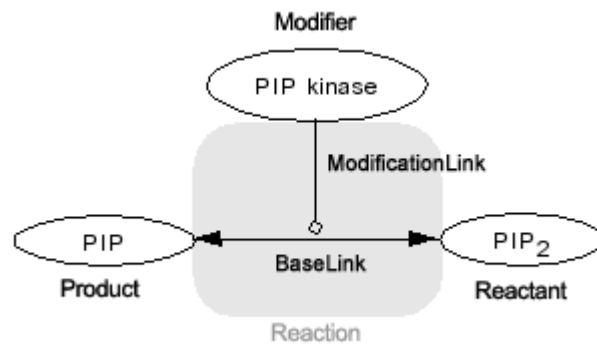
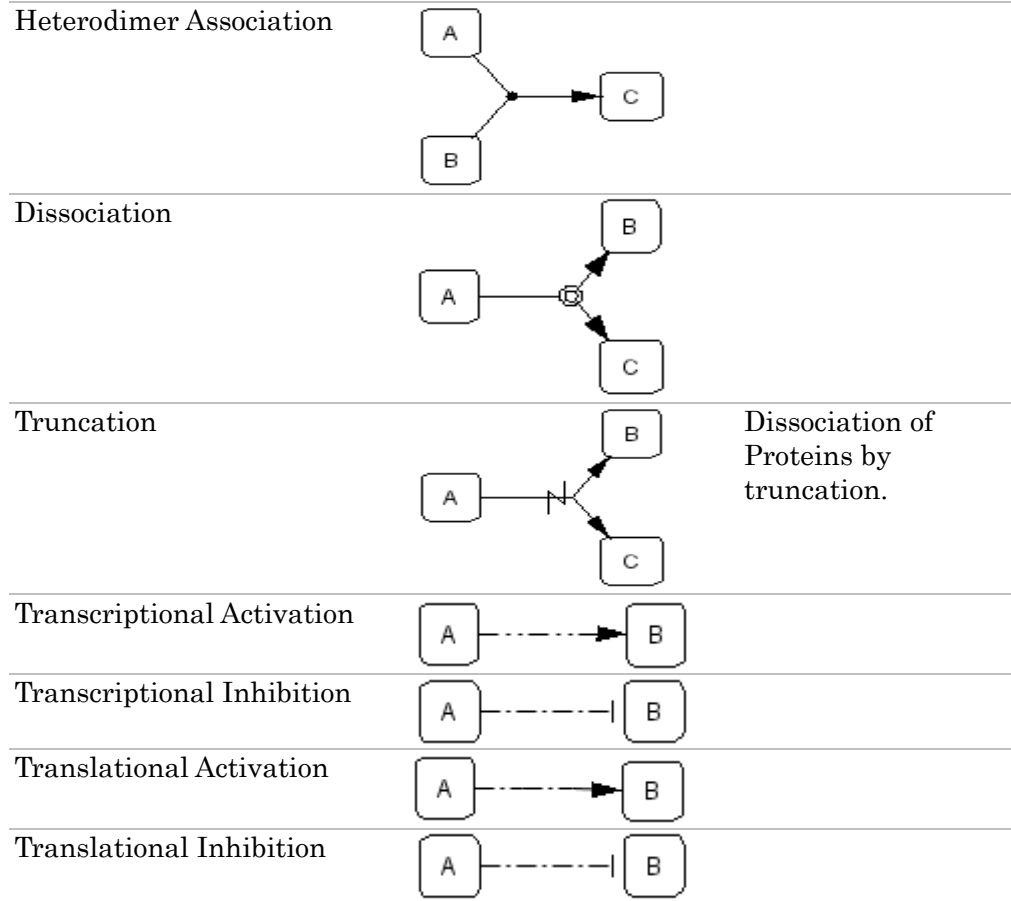

A1.2 Expressions

Here are symbols acquiring additional semantics by shape, combination of symbols, or change in drawings. Active t the **Species** is active.

Active		
Channel Open		Activate Ion_Channel.
Homodimer formed		Double-click the Species to open the identity dialog, then set the Homodimer number.
COMPLEX		 “Change Complex View” to toggle to show/hide the contents of the Complex
Hypothetical Species		Double-click the Species to open the identity dialog, then check the hypothetical ON.
Reversible Reactions		Double-click the Reaction, then set “reversible” to “true”
Bidirectional Reactions		Simply draw two state transitions and reposition them
Homodimer formation		Click the icon of Homodimer formation.
Degradation of Species		Click the icon of Degradation.

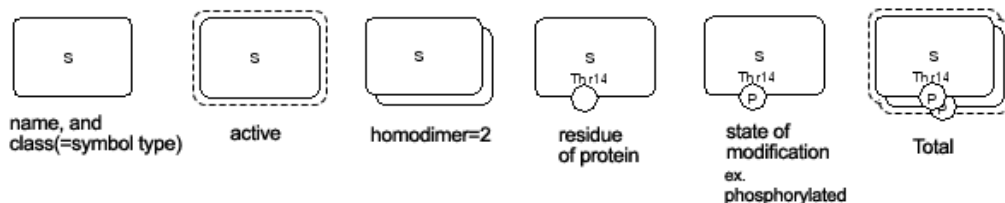

Appendix 2: Sample Files for Graphical Notation

To explore new graphical notation scheme most, there are the sample files available in this preview version. Please open the files in the /samples directory and try editing the model.

A2.1 Examples used in this document

Complex.xml

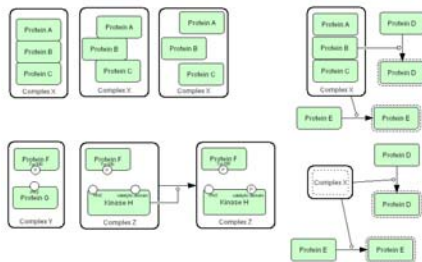

geneRNA.xml

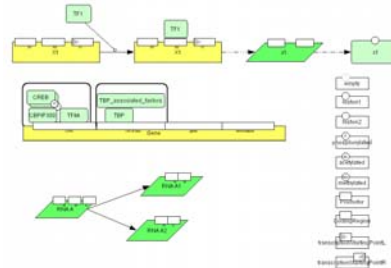

ReactionShape.xml

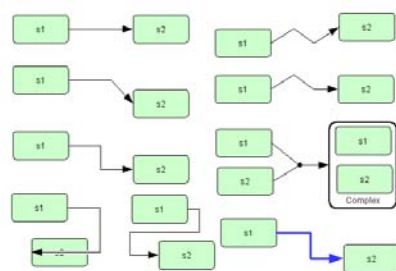

A2.2 Examples for Graphical Notation

These are the examples used in the paper "The Process Diagram for Graphical Representation of Biological Networks," Kitano, H. et al. Nature Biotechnology, August 2005.

Fig1b_ProcessDiagram_3

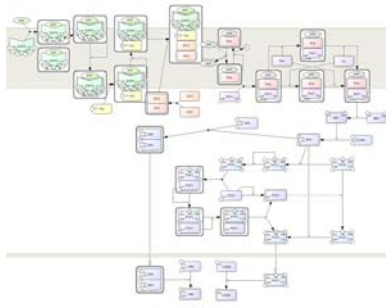

Fig3abcd_AndOr_3

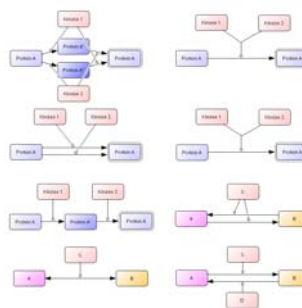
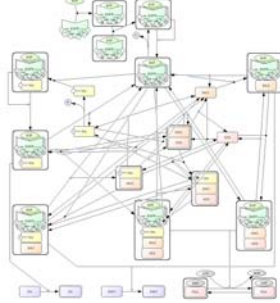
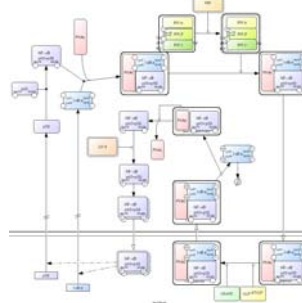

Fig3e_EGFR_league_3



SuplFig3_NF-kappaB(p65+p50)_3



SuplFig2_GPCR beta2-AR_3

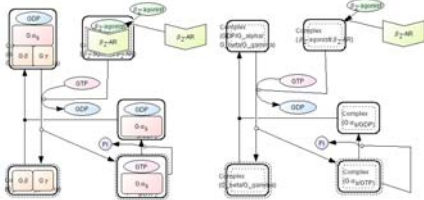

SuplFig4b_transcription_3

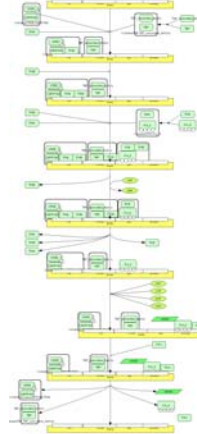

SuplFig4a_TranscriptionTranslation_3

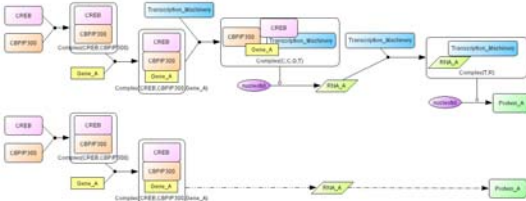

SuplFig5_StructureofComplex_3

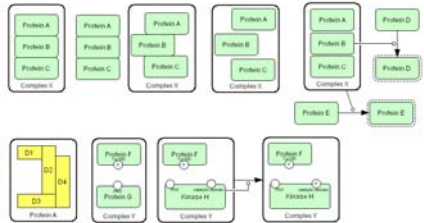

SuplFig7_M-Phase_3

